

Mauselektronik für die Positionierung des Roboters mittels Mikrocontroller

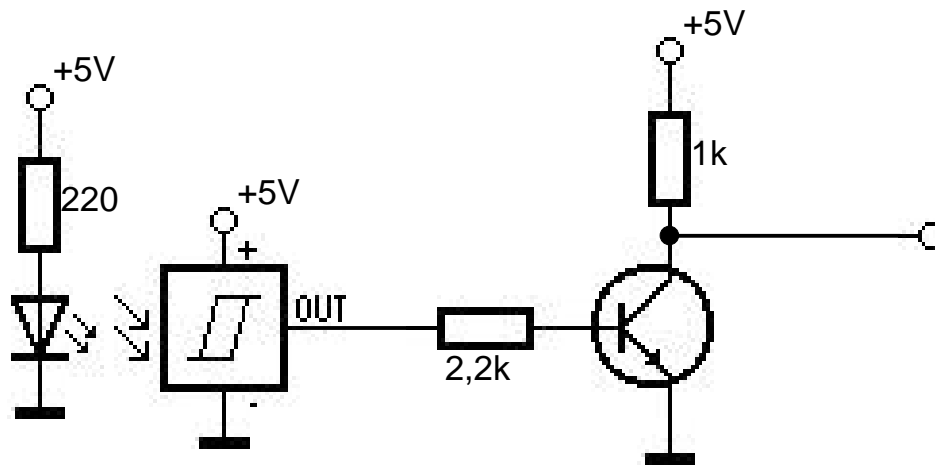

horizontal

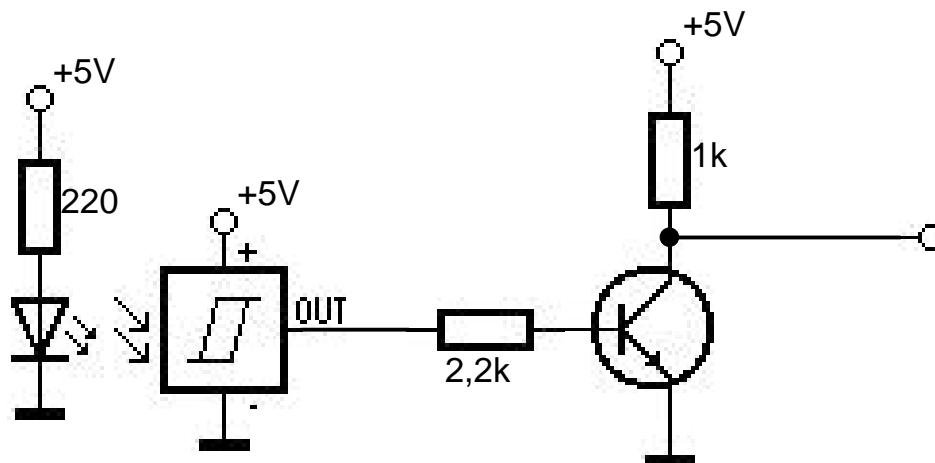

vertikal